

1.8V-5.5V, 70µA, RRIO Zero-Drift, Instrumentation Amplifier

Features

- Low offset Voltage: 25µV (Max.)
- Zero Drift: 0.05µV/°C
- Low Quiescent Current: 70µA
- Low Input Bias Current: 200pA (Max.)
- Rail-to-Rail Input and Output (RRIO)
- Operates on 1.8V ~ 5.5V Supplies
- -3dB Bandwidth: 250kHz
- Slew Rate: 0.25V/µs
- Unity Gain Stable
- No Phase Reversal
- Extended Temperature Ranges
From -40°C to +125°C
- Available in MSOP8/SOP8

Applications

- Medical Instrumentation
- ECG and RTD Sensor Amplifiers
- Data Acquisition
- Thermocouple Amplifiers
- Bridge Amplifiers
- Pressure Sensors

General Description

The COSINA333 is a micro power, zero-drift instrumentation amplifier operated on 1.8 to 5.5 supplies. It has both rail-to-rail input and output range. The output voltage swing extends to within 2mV of each rail, providing the maximum output dynamic range. A single external resistor sets any gain from 1 to 1000.

The COSINA333 uses auto-calibration technique to provide very low offset voltage (less than 25µV maximum) and near zero drift over temperature. Low quiescent supply current of 70µA and very low input bias current make the device an ideal choice for low offset, low power consumption and high impedance applications.

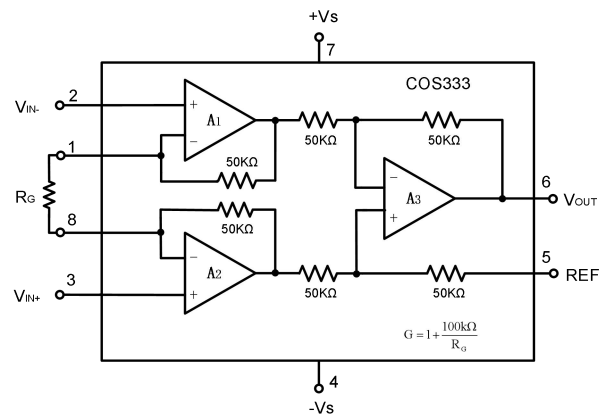

Block Diagram

Rev1.2
Copyright©2018 Cosine Nanoelectronics Inc. All rights reserved

The information provided here is believed to be accurate and reliable. Cosine Nanoelectronics assumes no reliability for inaccuracies and omissions. Specifications described and contained here are subjected to change without notice on the purpose of improving the design and performance. All of this information described herein should not be implied or granted for any third party.

1. Pin Configuration and Functions

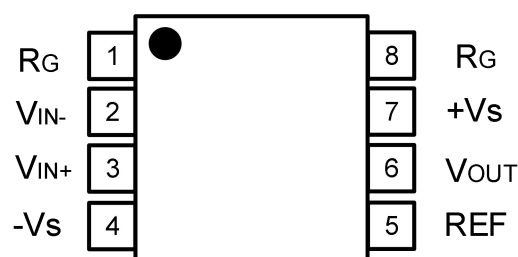

Pin Functions

Pin	Name	I/O	Description
1,8	R_G	-	Gain setting pin. For gains greater than 1, place a gain resistor between pin1 & 8
2	V_{IN-}	I	Negative input
3	V_{IN+}	I	Positive input
4	$-V_S$	P	Negative supply
5	REF	I	Reference input. This Pin must be driven by low impedance or connected to ground
6	V_{OUT}	O	Output
7	$+V_S$	P	Positive supply

2. Product Specification

2.1 Absolute Maximum Ratings ^(1,2)

Parameter	Rating	Units
Power Supply: $V+$ to $V-$	6	V
Differential Input Voltage Range	± 6	V
Common Mode Input voltage Range ⁽²⁾	$V+$ to $V-$	V
Output Current	50	mA
Storage Temperature Range	-65 to 150	$^{\circ}\text{C}$
Junction Temperature	150	$^{\circ}\text{C}$
Operating Temperature Range	-40 to 125	$^{\circ}\text{C}$
ESD Susceptibility, HBM	2000	V

(1) Stresses exceeding the absolute maximum ratings may damage the device. The device may not function or be operable above the recommended operating conditions and stressing the parts to these levels is not recommended. In addition, extended exposure to stresses above the recommended operating conditions may affect device reliability. The absolute maximum ratings are stress ratings only.

(2) Input terminals are diode-clamped to the power-supply rails. Input signals that can swing more than 0.5V beyond the supply rails should be current-limited to 10mA or less.

2.2 Thermal Data

Parameter	Rating	Unit
Package Thermal Resistance	206 (MSOP8) 155 (SOP8)	°C/W

2.3 Recommended Operating Conditions

Parameter	Rating	Unit
DC Supply Voltage	1.8V ~ 5.5V	V
	±0.9V ~ ± 2.75V	V
Input common-mode voltage range	-Vs ~ +Vs	V
Operating ambient temperature	-40 to +85	°C

2.4 Electrical Characteristics

(+Vs=+5V, -Vs=0V, V_{REF}=2.5V, T_A=+25°C, R_L=10kΩ and G=1, unless otherwise noted)

Parameter	Symbol	Conditions	Min	Typ	Max	Unit
Input Characteristics						
Input Offset Voltage	V _{OS}	COSINA333A		±5	±25	μV
		COSINA333B		±25	±150	μV
Input Offset Voltage Drift	ΔV _{OS} /ΔT	-40 to 125°C		0.01	0.05	μV/°C
Input Bias Current	I _B			±3	±200	pA
Input Offset Current	I _{OS}			±3	±200	pA
Common-Mode Voltage Range	V _{CM}	V _O = 0, see Figure3.2	-Vs+0.1		+Vs-0.1	V
Common-Mode Rejection Ratio	CMRR	V _{CM} =0.1V to 4.9V		120		dB
Open-Loop Voltage Gain	A _{OL}	V _O =0.2V to 4.8V		145		dB

Output Characteristics						
Output Voltage Swing from Rail		$R_L=100k\Omega$		2		mV
		$R_L=10k\Omega$		20		mV
Short-Circuit Current	I_{SR}	Sourcing		15		mA
	I_{SK}	Sinking		-15		mA
Power Supply						
Operating Voltage Range	V_S		1.8		5.5	V
			± 0.9		± 2.75	V
Power Supply Rejection Ratio	PSRR		120	130		dB
Quiescent Current / Amplifier	I_Q			70		μA
Frequency Response						
Bandwidth, -3dB	BW	G=1		250		kHz
		G=10		42		kHz
		G=100		4		kHz
		G=1000		400		Hz
Dynamic Performance						
Slew Rate	SR	G=1		0.25		V/ μs
		G=100		0.05		V/ μs
Noise Performance						
Voltage Noise Density	e_n	f=1kHz		50		nV/ \sqrt{Hz}
REFERENCE INPUT						
Voltage Range			-Vs		+Vs	V
Reference Input Impedance	R_{IN}			100		k Ω

3. Application Notes

3.1 Overview

The COSINA333 is a micro power, zero-drift instrumentation amplifier operated on 1.8 to 5.5 supplies. It has both rail-to-rail input and output range. The output voltage swing extends to within 2mV of each rail, providing the maximum output dynamic range. A single external resistor sets any gain from 1 to 1000. The COSINA333 uses auto-calibration technique to provide very low offset voltage (less than 25µV maximum) and near zero drift over temperature. Low power and small size make it ideal for a wide range of portable applications.

3.2 Application Information

Figure 3.1 shows the basic connections required for operation of the COSINA333. The output is referred to the REF terminal, which is normally grounded. The REF pin connection must be low-impedance to assure good common-mode rejection. A resistance of 8Ω in series with the REF pin will cause a 80dB CMRR degradation.

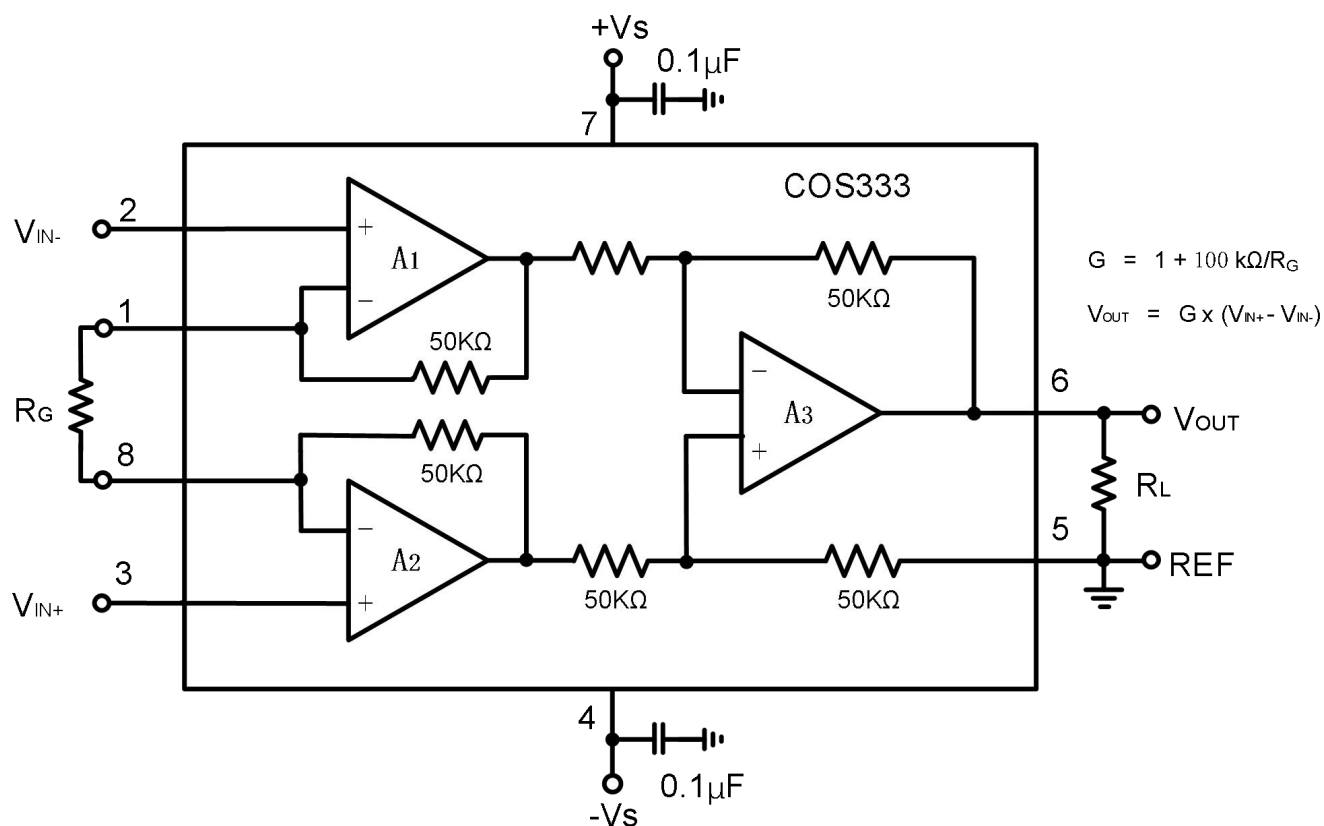

Figure 3.1 Basic Connection

Gain of the COSINA333 is set by connecting a single external resistor, R_G , between pins 1 and 8:

$$G = 1 + 100 \text{ k}\Omega/R_G$$

Commonly used gains and resistor values are shown in following Table 3.1. Low resistor values required for high gain can make wiring resistance contribute to the gain error.

Table 3.1 Gain and Corresponding Resistor Values

Desired Gain $G(V/V)$	COSINA333: $G=1 + 100 \text{ k}\Omega/R_G$	
	$R_G(\Omega)$	Nearest 1% $R_G(\Omega)$
1	NC	NC
2	100k	100k
5	25k	24.9k
10	11.1k	11k
20	5.26k	5.23k
50	2.04k	2.05k
100	1.01k	1k
200	502.5	499
500	200.4	200
1000	100.1	100

3.3 Input Common-Mode Range

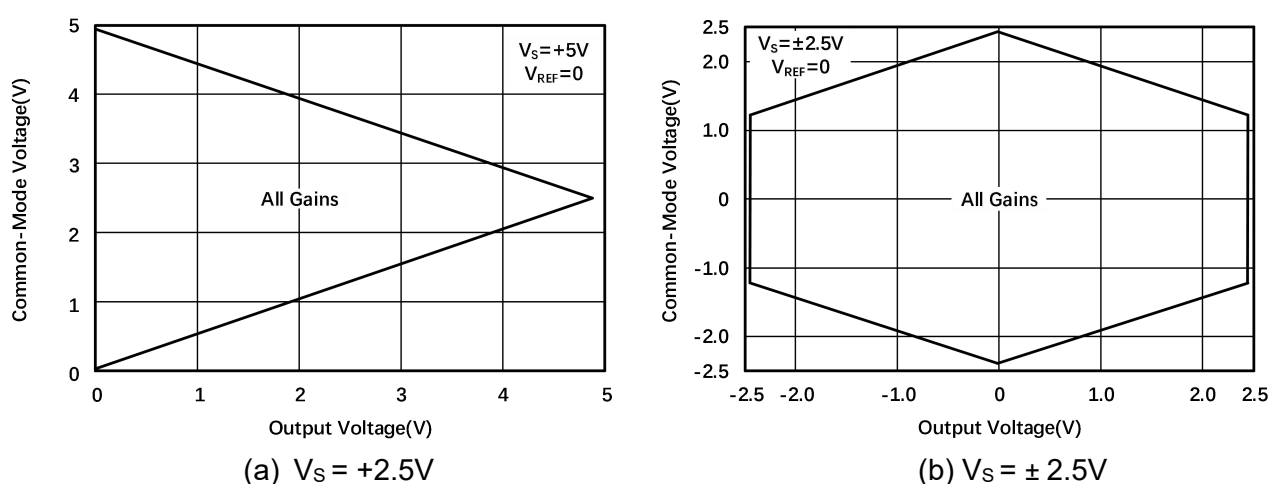

Figure 3.2 Typical Common-Mode Range vs Output Voltage

Since a differential input voltage causes the output voltage to increase, the linear input range is limited by the output voltage swing of amplifiers A1 and A2. Thus, the linear common-mode input range is related to the output voltage of the complete amplifier. This behavior also depends on supply voltage as shown in Figure 3.2.

3.4 Power-Supply Bypassing and Layout

The COSINA333 operates from a single +1.8V to +5.5V supply or dual $\pm 0.9V$ to $\pm 2.75V$ supplies. For single-supply operation, bypass the power supply +Vs with a 0.1 μ F ceramic capacitor which should be placed close to the +Vs pin. For dual-supply operation, both the +Vs and the -Vs supplies should be bypassed to ground with separate 0.1 μ F ceramic capacitors. 2.2 μ F tantalum capacitor can be added for better performance.

The length of the current path is directly proportional to the magnitude of parasitic inductances and thus the high frequency impedance of the path. High speed currents in an inductive ground return create an unwanted voltage noise. Broad ground plane areas will reduce the parasitic inductance. Thus a ground plane layer is important for high speed circuit design.

4. Ordering Information

Model	Order Number	Package	Package Option	Marking Information
COSINA333	COSINA333MRA	MSOP-8	Tape and Reel, 3000	COS333
	COSINA333MRB	MSOP-8	Tape and Reel, 3000	COS333

5. Package Information

5.1 MSOP8 (Package Outline Dimensions)

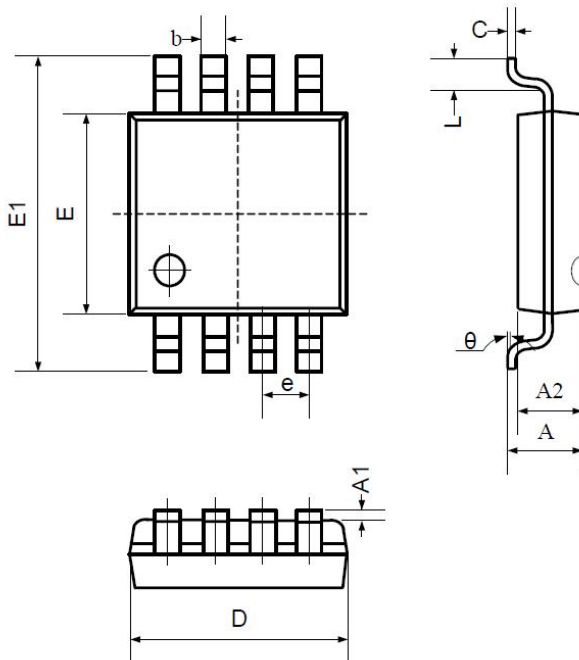

Symbol	Dimensions In Millimeters		Dimensions In Inches	
	Min	Max	Min	Max
A	0.800	1.200	0.031	0.047
A1	0.000	0.200	0.000	0.008
A2	0.760	0.970	0.030	0.038
b	0.30 TYP		0.012 TYP	
c	0.15 TYP		0.006 TYP	
D	2.900	3.100	0.114	0.122
e	0.65 TYP		0.026 TYP	
E	2.900	3.100	0.114	0.122
E1	4.700	5.100	0.185	0.201
L	0.410	0.650	0.016	0.026
θ	0°	6°	0°	6°

5.2 SOP8 (Package Outline Dimensions)

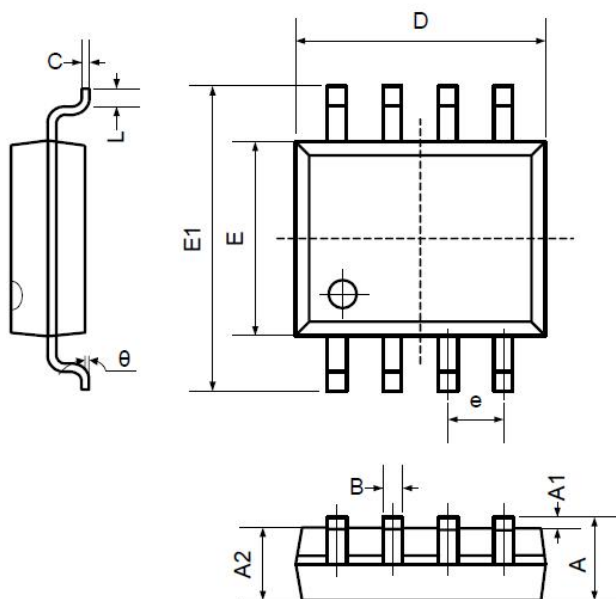

Symbol	Dimensions In Millimeters		Dimensions In Inches	
	Min	Max	Min	Max
A	1.350	1.750	0.053	0.069
A1	0.100	0.250	0.004	0.010
A2	1.350	1.550	0.053	0.061
B	0.330	0.510	0.013	0.020
C	0.190	0.250	0.007	0.010
D	4.780	5.000	0.188	0.197
E	3.800	4.000	0.150	0.157
E1	5.800	6.300	0.228	0.248
e	1.270TYP		0.050TYP	
L	0.400	1.270	0.016	0.050
θ	0°	8°	0°	8°